

RISER CONSTRUCTED AS SPECIFIED. STANDARD 1'-8", 6" TALL. TUF-TITE OR OR EQUIVALENT. (TYP. 2)

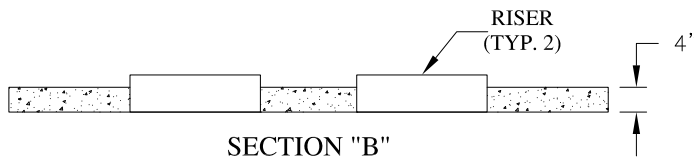

SECTION "B"
AQUA KLEAR LID

SPECIFICATIONS

CONCRETE - 6000 PSI minimum in 28 days.

REINFORCEMENT - 6X6 10 gauge

ASTM A185 65 KSI plain finish cont.

around perimeter of tank, #3 bars (Grade 60) rebar, per engineering spec. as required for tanks design.

LID REINFORCEMENT - #3 rebar 6" center, both ways plus a mat on 6X6 10 gauge wire.

PIPE PENETRATIONS - Inlet and outlet seals water tight that meet ASTM C923.

PARTITION WALLS - If present, is poured monolithically.

INSTALLATION - By contractor per code with minimum of 12" on all sides of unit is required.

Depth of base and material shall meet the specifications and requirements for the type of soil at the setting location. The leveling of the material will prevent tank from cracking after filling with water.

BACK FILL - Before filling with water! This must be done on all sides by lowering sand.

DO NOT PUSH FROM SIDES.

TANK WARRANTY - Limited to replacement for 1 year.

Full warranty provided with tank purchase at location

and at www.texasprecast.net

Approx. Capacity -884 gallons

Approx. Weight 7560 lbs.

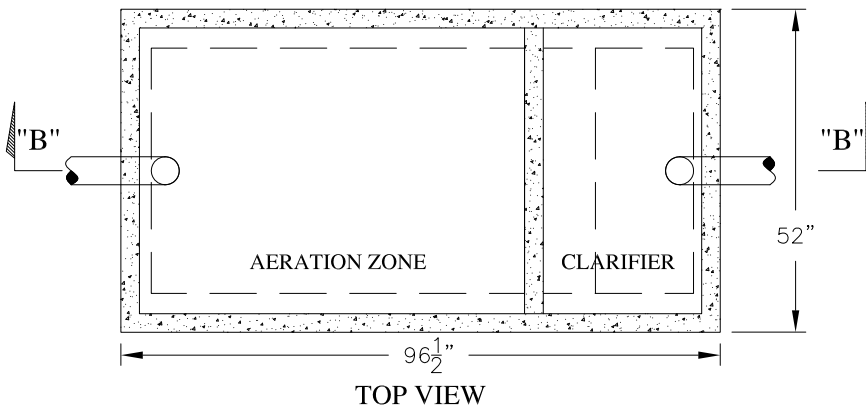

TOP VIEW

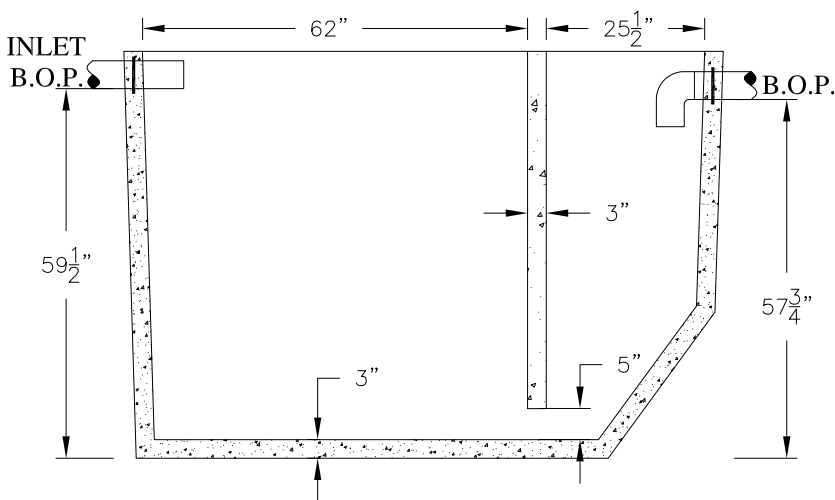

FRONT VIEW
SECTION "A"

AQUA KLEAR BODY

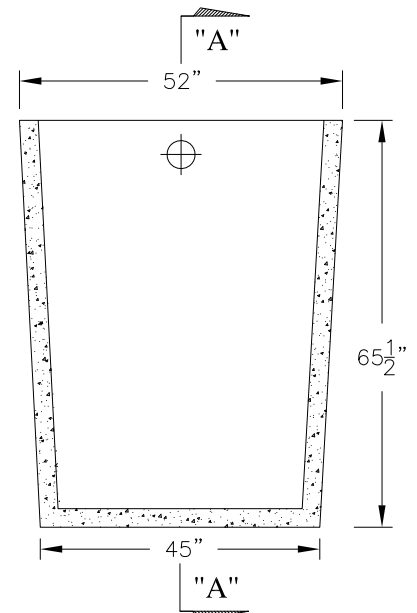

RIGHT SIDE VIEW

WWW.TEXASPRECAST.NET

TOLL FREE: 800-633-3235
PHONE: 409-925-2502

TEXAS PRECAST, L.L.C.

18303 HIGHWAY 6
SANTA FE, TEXAS 77510

**MODEL
AK600C**